

3.1 Electric Current

1 ampere of electric current is produced when 1 coulomb of electric charge passes through the cross-section of the conductor in 1 second.

In a steady circuit, electrical potential at all points of a conductor remain constant with respect to time. In such a steady circuit, the amount of electric charge entering any cross-sectional area of a conductor in a given time interval is equal to the amount of electric charge leaving that cross-sectional area in the same interval of time. In other words, charge never accumulates at any point in the conductor. Also the electric charge is neither created nor destroyed at any point in the conductor. This means that electric charge is conserved.

Let ΔQ amount of electric charge flow through any cross - sectional area of the conductor in time interval Δt . The average electric current flowing in time interval Δt is given by

$$\langle I \rangle = \frac{\Delta Q}{\Delta t}$$

The instantaneous electric current at time t is given by

$$I = \lim_{\Delta t \rightarrow 0} \frac{\Delta Q}{\Delta t} = \frac{dQ}{dt}$$

Electric current is a fundamental quantity in S.I. unit and its symbol is A meaning ampere. Smaller units of the current are milliampere ($\text{mA} = 10^{-3} \text{ A}$) and microampere ($\mu\text{A} = 10^{-6} \text{ A}$).

Current density

The electric current density near any point is defined as the amount of electric current flowing perpendicularly through the unit cross - sectional area near that point.

- Let \vec{J} be the electric current density at every point on the cross - sectional area,
- P be some point of the curved cross - sectional area of the conductor as shown in the figure,
- $\vec{\Delta a}$ be the area vector of the surface near point P, component of which in the direction of the current is $\Delta a \cos \theta$, where
- θ is the angle between the area vector and the direction of the current.

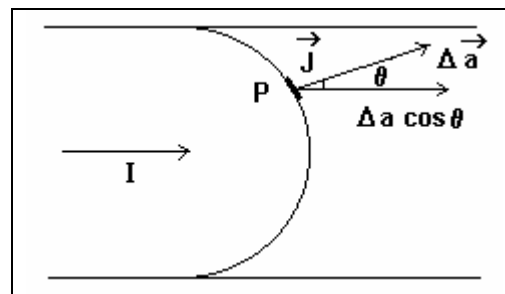

Therefore, average current density near point P,

$$\langle J \rangle = \frac{\Delta I}{\Delta a \cos \theta} \quad \text{where } \Delta I \text{ is electric current flowing through the small area element near point P.}$$

Therefore, electric current density,

$$J = \lim_{\Delta a \rightarrow 0} \frac{\Delta I}{\Delta a \cos \theta} = \frac{dI}{da \cos \theta} \quad \therefore dI = J da \cos \theta = \vec{J} \cdot \vec{da}$$

Integrating,

$$I = \int dI = \int_a^{\rightarrow} \vec{J} \cdot d\vec{a} = J \int da = JA$$

$$\therefore J = \frac{I}{A} \quad \text{where } A = \text{the entire cross-sectional area}$$

3.2 Electromotive Force and Terminal Voltage

The potential difference between the two poles of an electric cell is defined as the work done by the non-electrical force (due to chemical process taking place inside the cell) in moving a unit positive electric charge from a negative pole towards the positive pole.

The energy gained by the unit positive charge due to the non-electrical force, in moving it from the negative pole towards the positive pole, is called the emf (electromotive force) of the electric cell. Its unit is joule / coulomb (= volt).

When the poles of the electric cell are connected externally by a conducting wire, current starts flowing in the circuit. The direction of the conventional current is from the positive pole to the negative pole of the cell in the conducting wire. Actually, electrons move from the negative pole to the positive pole of the cell in the conducting wire. Inside the cell, current is due to the movement of positive ions towards the positive pole and negative ions towards the negative pole of the cell. During the motion inside the cell, the charges have to overcome the resistance offered by the materials of the cell. This resistance is called the internal resistance, r , of the cell. Some of the energy gained by the positive charge due to the work done by the non-electrical force is dissipated as heat in overcoming the internal resistance of the cell. This reduces its overall energy in comparison with open circuit condition. Hence, the p.d. between the poles of the cell is slightly lower when current is flowing as compared to the open circuit condition. This reduced p.d. is called the terminal voltage of the cell.

The relation between the emf (ϵ) and the terminal voltage (V) is

$$V = \epsilon - Ir$$

3.3 (a) Ohm's Law

The ratio of the potential difference (V) between the two ends of the conductor, kept in a fixed physical condition, and the electric current (I) flowing through it is constant. This statement is called Ohm's Law. This ratio is called the resistance (R) of the conductor. Its unit is ohm and symbol is Ω .

$$R \text{ (ohm)} = \frac{V \text{ (volt)}}{I \text{ (ampere)}}$$

$1/R$ is called the conductance of the material. Its unit is mho and symbol is \mathfrak{S} .

Metals, some insulators and many electrical components obey Ohm's law to perfection, but not all materials. The graph of I vs. V will be a straight line for a conductor obeying Ohm's law at a constant temperature, but the resistance of the conductor changes with temperature.

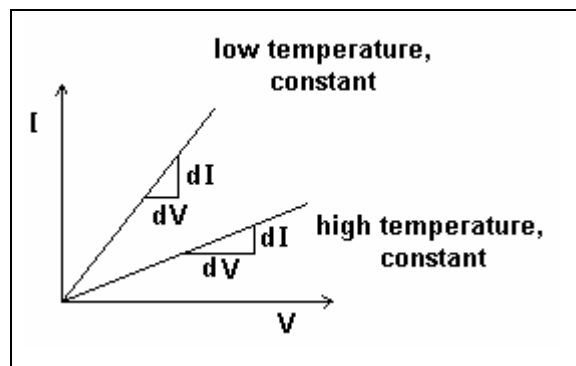

3.3 (b) Resistivity

Resistance (R) of a conductor varies directly as its length (l) and inversely as its cross-sectional area (A) at a given temperature.

$$\therefore R \propto l \text{ and } R \propto \frac{1}{A} \Rightarrow R = \rho \frac{l}{A}$$

where the constant ρ is known as the resistivity of the material. Its value depends on the type, temperature and the pressure existing on the given conductor. Its unit is ohm-meter ($\Omega \text{ m}$).

Resistivity of the material of a conductor at a given temperature and pressure is defined as its resistance per unit length per unit cross-sectional area.

Conductivity is the inverse of resistivity. Its unit is mho- m^{-1} (or siemen - m^{-1}) and its symbol is σ (= S m^{-1}).

3.3 (c) Colour Code for Carbon Resistors

There are two types of resistors: (i) wire wound and (ii) carbon resistors. Wire wound resistors are made of manganine, constantan and nichrome wires wound on a proper base. Carbon resistors are small, cheap and widely used in electronic circuits.

Colour	Digit	10^n	Colour	Digit	10^n	Tolerance
Black	0	10^0	Violet	7	10^7	
Brown	1	10^1	Grey	8	10^8	
Red	2	10^2	White	9	10^9	
Orange	3	10^3				
Yellow	4	10^4	Gold		10^{-1}	$\pm 5\%$
Green	5	10^5	Silver		10^{-2}	$\pm 10\%$
Blue	6	10^6	No colour			$\pm 20\%$

The diagram shows a cylindrical carbon resistor with four color bands. From left to right, the bands are yellow, violet, brown, and golden. The yellow band is labeled 'yellow', the violet band is labeled 'violet', the brown band is labeled 'brown', and the golden band is labeled 'golden'.

Slogan to memorize colour code - " B B ROY Goes to Bombay Via Gate-Way "

The value of the carbon resistor can be known from the colour bands on it. Refer to the above figure and the table.

The first band yellow has number 4 and the second band violet has number 7. This forms number 47. The third band brown means 10^1 as read from the third column of the table. 47×10^1 gives 470Ω as the value of the resistor. The last band of golden colour gives tolerance of $\pm 5\%$. Thus, true value of the resistor will be $470 \pm 5\% \Omega$.

3.4 Origin of Resistivity

In vacuum, electrons have accelerated motion due to electric field. Contrary to this, electrons move with some average velocity due to electric field in a conductor under steady state of the flow of the current.

Outer orbit electrons of metals (known as valence electrons) are called free electrons as they are free to move in the entire space occupied by the piece of metal. The positively charged ions left behind oscillate about their lattice positions with energy depending upon temperature of metals. The free electrons move randomly in the space between the ions. In the absence of any electric field, the average number of electrons crossing any cross-section of a conductor being zero, there is no current. When potential difference is applied between the two ends of the conductor, electrons are dragged towards the positive end. If E is the electric field along the length of the conductor, an electron experiences a force eE opposite to the direction of the electric field as it is negatively charged and starts moving with an acceleration, $a = eE/m$. During this motion, electrons collide with constantly oscillating positive ions. With every such collision, they become almost stationary and start their motion again from zero velocity. The net result is that they move with some average velocity known as drift velocity, v_d , resulting in current.

If τ is the average time (known as relaxation time) between two successive collisions of the electron with the ions, then

$$v_d = \frac{eE}{m} \tau \quad \dots (1)$$

Now, the current density J is directly proportional to E . $\therefore J \propto E \Rightarrow J = \sigma E$... (2)
 σ is called the conductivity of the material of conductor.

Calculating J :

If N = number of electrons crossing unit cross-sectional area of the conductor in 1 s, then
 $J = Ne = ne v_d$... (3)

where n = number of free electrons per unit volume of the conductor = N/v_d

Putting the values of J and v_d from equations (2) and (1) in equation (3), we have

$$\sigma E = ne \frac{eE\tau}{m} \quad \therefore \sigma = \frac{1}{\rho} = \frac{ne^2 \tau}{m} \quad \therefore \rho = \frac{m}{ne^2 \tau} \quad \dots (4)$$

With increase of temperature, ions oscillate faster resulting in decrease in relaxation time, τ , and increase in resistivity, ρ .

Vectorially, $\vec{J} = nq\vec{v}_d$. If q is positive, then \vec{J} and \vec{v}_d will have the same direction and if q is negative, then they will have opposite directions.

3.4 (a) Mobility

The conductivity of any material is due to mobile charge carriers which can be electrons in a conductor or electrons and ions produced by ionization of air molecules or the positive and negative ions in electrolytes. In semi-conductors, electrons and holes (hole is the deficiency of electron in the covalent bond which behaves as a positively charged particle) are responsible for the flow of current.

Mobility, μ , of a charged particle is defined as its drift velocity per unit electric field intensity.

Thus,
$$\mu = \frac{v_d}{E}$$

From equation, $nev_d = \sigma E$ for an electron moving in a conductor, we have $\frac{v_d}{E} = \frac{\sigma}{ne}$.

$\therefore \mu = \frac{\sigma}{ne}$, where σ is the conductivity and n is the number of free electrons / unit volume.

Thus, for an electron, $\sigma_e = n_e e \mu_e$ and similarly for holes $\sigma_h = n_h e \mu_h$.

In a semi-conductor, the holes and electrons both constitute current in the same direction.

Hence, total conductivity,

$$\sigma = \sigma_e + \sigma_h = n_e e \mu_e + n_h e \mu_h$$

3.5 Temperature Dependence of Resistivity

The resistivity of metallic conductors increases with temperature as under.

$\rho_\theta = \rho_0 [1 + \alpha(\theta - \theta_0)]$ where, ρ_0 = resistivity at some reference temperature θ_0

ρ_θ = resistivity at temperature θ and

α = temperature coefficient of resistivity and its unit is $(^\circ\text{C})^{-1}$.

(Note: Actually, the value of α depends on the reference temperature which is not mentioned in the text-book.)

Ignoring variations in dimensions of the conductor, the above equation can also be written for the resistance of the conductor as follows:

$$R_\theta = R_0 [1 + \alpha(\theta - \theta_0)]$$

The graph 1 shows resistivity vs. temperature for good conductors. At lower temperatures ($< 50 \text{ K}$), the graph is non-linear and becomes linear near the room temperature. At higher temperatures, it again becomes non-linear.

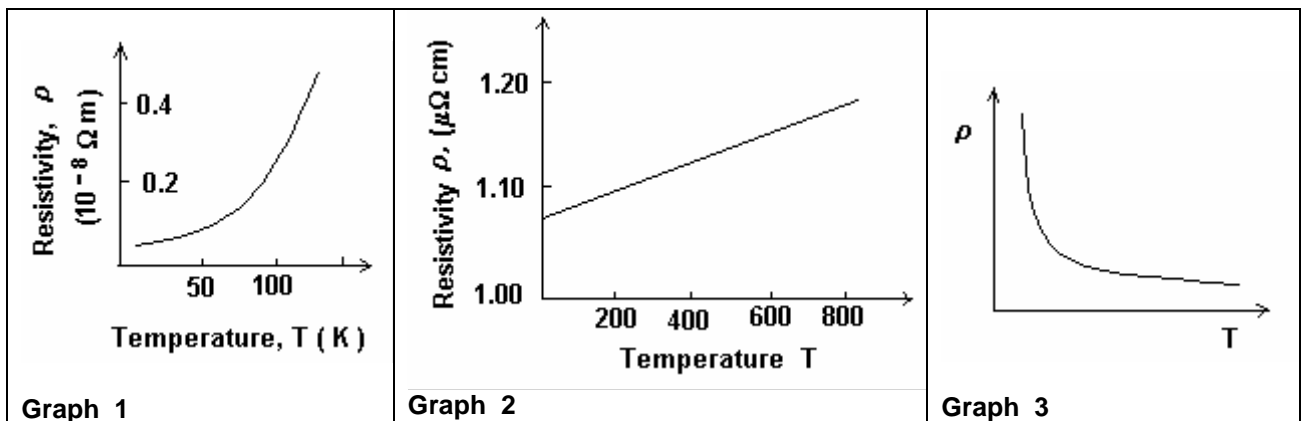

Nichrome (an alloy of nickel and chromium) has very high resistivity with low temperature dependence as shown in graph 2. Manganine (an alloy of copper, manganese and nickel) has resistivity which is almost constant with respect to the temperature. The resistivity of nichrome does not become zero even at absolute zero temperature, while the resistivity of pure metal becomes almost zero at absolute zero temperature which helps testing its purity.

Carbon, germanium, silicon and various other materials have negative value of α meaning that their resistivity decreases with temperature as shown in graph 3. Such materials are known as semi-conductors.

The relaxation time τ and to some extent the charged carrier density n , change with temperature in a semi-conductor and an insulator. The variation of n with temperature T is given by the equation

$$n_T = n_0 e^{-\frac{E_g}{k_B T}},$$

where E_g is the energy gap between the upper portion of the valence band and lower portion of the conduction band. k_B is the Boltzmann's constant. The equation suggests that for a semi-conductor, n increases with temperature thus increasing conductivity and reducing its resistivity.

3.6 Limitations of Ohm's Law

Many components in the electric circuit have the following V - I characteristics.

1. They are non-linear.
2. The absolute value of V depends on the polarity of V (i.e., it depends on its direction).
3. V can have more than one value for a given value of current.

These are the limitations of Ohm's law.

3.7 Superconductivity

"The resistance of certain materials becomes almost zero, when its temperature is lowered below certain fixed temperature (known as critical temperature T_c). The material in this situation is known as superconductor and this phenomenon is known as superconductivity."

Kamerlingh Onnes in 1911 showed that when the temperature of a specimen of mercury (Hg) is reduced to 4.3 K, its resistance reduces to 0.084Ω and at 3 K, it becomes $3 \times 10^{-6} \Omega$ which is almost one lakhth part of its resistance at 0°C . Many metals and alloys exhibit the property of superconductivity. Si, Ge, Se and Te are some of the semi-conductors which behave as super-conductors under high pressure and low temperatures.

When current flows through a superconductor, its resistance being almost zero, practically no electrical energy is lost as heat and the current is sustained over a long time interval.

The biggest hurdle in the commercial application of superconductors is the need for low temperature. Efforts are on by researchers all over the world to invent materials which can

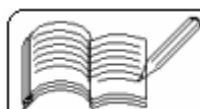

be used as superconductor at room temperature and thus transmission losses of electrical power can be minimized.

Scientists Bardeen, Cooper and Schrieffer explained the phenomenon of superconductivity using quantum mechanics. Their theory is known as BCS theory. This theory is based on prediction of attraction between electrons under special circumstances. Physicists Bendnorz and Muller prepared compounds of copper oxides in 1986 having critical temperature of 30 K for which they were awarded Nobel Prize. Thereafter, critical temperature upto 135 K has been reached. Such super-conductors are known as high critical temperature super-conductors (HTS). HTS has applications in thin film devices, electric transmission over long distances, levitating trains (which can achieve speeds of 550 km/h).

3.7 (a) Meissner Effect

<p>Meissner and Ochsenfeld discovered in 1933 that if a conducting material is kept in magnetic field at less than its critical temperature, the magnetic field lines are pushed away from it as shown in the figure. This effect is known as Meissner effect.</p> <p>It can be said from Meissner effect that the magnetic field inside the superconductor is zero.</p>	
--------------------------------------------------------------------------------------------------------------------------------------------------------------------------------------------------------------------------------------------------------------------------------------------------------------------------------------------------------------------------	--

3.8 Electric Circuits and Kirchhoff's Rules

Kirchhoff's First Rule:

“The algebraic sum of electric currents flowing through any junction is zero.”

Refer to the junction point O of the network as shown in the figure. I_1, I_2, \dots, I_5 , are the currents meeting at the junction point O. Let Q_1, Q_2, \dots, Q_5 be the corresponding charges flowing in time t.

Then, $I_1 = \frac{Q_1}{t}, I_2 = \frac{Q_2}{t}, \dots, I_5 = \frac{Q_5}{t}$.

The total electric charge flowing towards the junction point = $Q_1 + Q_3$ and the total electric charge flowing out of the junction point = $Q_2 + Q_4 + Q_5$ in the same time.

Hence, by the law of conservation of electric charge,

$$Q_1 + Q_3 = Q_2 + Q_4 + Q_5$$

$$\therefore I_1 t + I_3 t = I_2 t + I_4 t + I_5 t$$

$$\therefore I_1 + (-I_2) + I_3 + (-I_4) + (-I_5) = 0$$

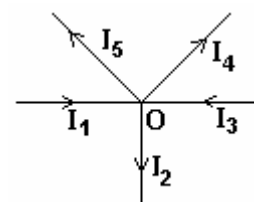

It is clear from the above result that the algebraic sum of electric currents meeting at a junction is zero.

Kirchhoff's Second Rule:

“The algebraic sum of the products of resistances and the corresponding currents flowing through them is equal to the algebraic sum of the emfs applied along the loop.”

Kirchhoff's second rule is based on the conservation of energy and the concept of the electric potential.

Consider a closed path ABCDA formed using resistors R_1, R_2, R_3, R_4 and batteries having emfs ϵ_1 and ϵ_2 .

The electric potential at any point in a steady circuit does not change with time. If V_A is the electric potential at point A, then on measuring the electric potential at various points in the closed path ABCDA and coming back to A, the electric potential would again be equal to V_A . This singular value of the electric potential is based on the law of conservation of energy.

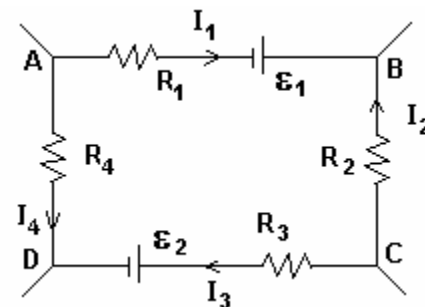

Starting from A, as we move in a clockwise direction in the loop, the electric potential reduces by I_1R_1 . This is because current flows from A to B which means that the end A of the resistor R_1 is at a higher potential. The potential increases by ϵ_1 as we move from negative terminal to positive terminal of battery having emf ϵ_1 . Potential increases on going from point B to point C through the resistor R_2 , as the direction of current is from C to B. Counting electric potential this way, on reaching the point A back, potential will be again V_A .

$$\therefore V_A - I_1R_1 + \epsilon_1 + I_2R_2 - I_3R_3 - \epsilon_2 + I_4R_4 = V_A$$

$$\therefore (-I_1R_1) + I_2R_2 + (-I_3R_3) + I_4R_4 = \epsilon_2 - \epsilon_1$$

This is the statement of Kirchhoff's second rule derived on the basis of the law of conservation of energy.

3.9 Series and Parallel Connections of Resistors

Series Connection:

When resistors are connected end to end as shown in the figure, the same amount of current flows through them and they are said to have been connected in series. In this type of connection, potential difference across each resistor is different and is proportional to the value of the resistor.

Applying Kirchhoff's second rule,

$$IR_1 + IR_2 + IR_3 = V$$

$$\therefore I(R_1 + R_2 + R_3) = V$$

$$\therefore R_1 + R_2 + R_3 = V/I \quad \dots \quad \dots \quad (1)$$

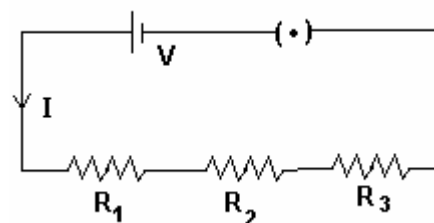

If these three resistors are replaced by a single resistance R such that the same current I flows through the battery as earlier, then R is called the equivalent resistance of the three resistors connected in series.

$$\therefore R = V/I \quad \dots \quad \dots \quad (2)$$

$$\therefore R = R_1 + R_2 + R_3 \quad [\text{from equations (1) and (2)}, \text{ and in general}$$

$$R = R_1 + R_2 + R_3 + \dots + R_n$$

The equivalent resistance of the resistors connected in series is greater than the greatest value of the resistors connected in series combination.

Parallel Connection:

When one of the ends of two or more resistors are connected to a single point and their other ends are connected to another common point in a circuit as shown in the figure, they are said to have been connected in parallel. In such a connection, the main line current distributes in the resistors, but the potential difference across them is the same.

Applying Kirchhoff's second rule to the loops, A - V - B - R₁ - A, A - V - B - R₂ - A and A - V - B - R₃ - A,

$$V = I_1 R_1 = I_2 R_2 = I_3 R_3$$

$$\therefore I_1 = \frac{V}{R_1}, \quad I_2 = \frac{V}{R_2} \quad \text{and} \quad I_3 = \frac{V}{R_3}$$

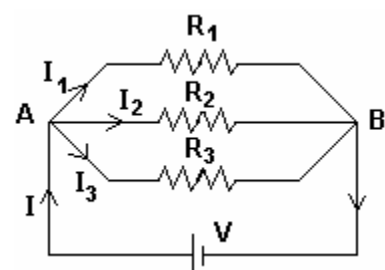

Applying Kirchhoff's first rule to the junction A,

$$I = I_1 + I_2 + I_3 = V \left[\frac{1}{R_1} + \frac{1}{R_2} + \frac{1}{R_3} \right] \therefore \frac{I}{V} = \left[\frac{1}{R_1} + \frac{1}{R_2} + \frac{1}{R_3} \right] \dots (1)$$

If the parallel combination of resistors is replaced by a single resistor R whose value is such that the main line current I remains the same, then R is called the equivalent resistance of the three resistors connected in parallel. In that case,

$$V = IR \quad \therefore \frac{I}{V} = \frac{1}{R} \quad \dots \quad \dots (2)$$

$$\therefore \frac{1}{R} = \frac{1}{R_1} + \frac{1}{R_2} + \frac{1}{R_3} \quad [\text{from equations (1) and (2)}, \text{ and in general}$$

$$\therefore \frac{1}{R} = \frac{1}{R_1} + \frac{1}{R_2} + \dots + \frac{1}{R_n}$$

The equivalent resistance of the resistors connected in parallel is less than the least value of the resistors connected in parallel combination.

3.10 Measurement of Voltage, Current and Resistance

3.10 (a) Ammeter

Ammeter is used for measuring current. Galvanometer is a current sensing device which is used for this purpose. However, there are two practical difficulties in using galvanometer as an ammeter:

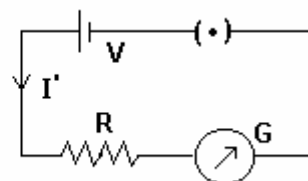
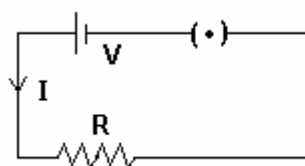

- (1) If we want to measure the current flowing through the resistor R of the circuit shown in the figure, the current measuring instrument is to be connected in series with it as shown in the next figure. This adds resistance G of the instrument in the circuit thereby altering the current in the resistor from the original value I to I'.
- (2) Further, a moving coil galvanometer is very sensitive and even a small current through it gives full scale deflection. Also the heat (I^2Gt) produced in it due to large current can damage its coil.

To overcome these problems, a low value resistance called shunt is connected in parallel to the galvanometer. As its value is much smaller than G, most of the current flows through it and the galvanometer does not get damaged. Moreover, the equivalent resistance of the modified galvanometer is lower than that of the shunt which when connected in the circuit does not alter its resistance appreciably and hence the true value of the current is measured.

Formula of Shunt

Let I_G = maximum current capacity of the galvanometer,

I = desired maximum current in the ammeter

S = necessary value of the shunt

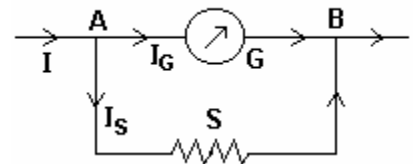

The value of the shunt should be so selected that the current I_G flows through the galvanometer and the balance $I - I_G = I_S$ flows through the shunt as shown in the figure.

Applying Kirchhoff's second rule to the loop,

www.schoolnotes4u.com

$$- I_G G + (I - I_G) S = 0 \quad \therefore S = \frac{G I_G}{I - I_G}$$

3.10 (b) Voltmeter

Voltmeter is used to measure the potential difference between any two points of a circuit. Galvanometer with suitable modification is used for this purpose. However, there are two practical difficulties in using galvanometer as a voltmeter:

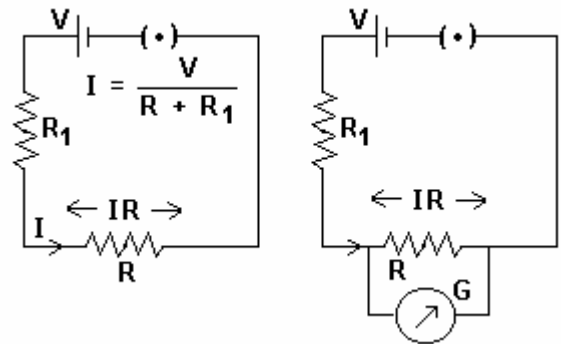

- (1) To measure potential difference across a circuit element, galvanometer has to be connected in parallel to it. This alters the resistance of the circuit and the current flowing through the circuit element and hence the potential difference across it.
- (2) Further, the galvanometer being a sensitive instrument, a large current can damage its coil.

To overcome these problems, a high value resistance called series resistance is connected in series with the galvanometer. If G is the resistance of the modified galvanometer, the new equivalent resistance of the circuit will be

$$R' = R_1 + \frac{RG}{R + G} \quad \text{As } G \gg R, \text{ ignoring } R, \quad R + G \cong G$$

$$\therefore R' = R_1 + \frac{RG}{G} \quad \therefore R' = R_1 + R$$

which is the same as the equivalent resistance of the original circuit.

Thus, resistance of the circuit is not changed much and as the value of G is large, most of the current flows through R which helps to measure correct value of IR. Moreover, very small current flows through the galvanometer due to its large resistance and is thus protected.

Deriving formula for the Series Resistance

Let I_G = maximum current capacity of the galvanometer,

G = resistance of galvanometer,

V = desired maximum voltage in the voltmeter

R_S = necessary value of the series resistance

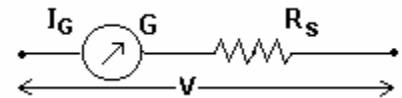

Applying Ohm's law to the modified galvanometer as shown in the figure,

$$I_G (G + R_S) = V$$

$$\therefore R_S = \frac{V}{I_G} - G$$

3.10 (c) Wheatstone Bridge

The network shown in the figure is known as Wheatstone bridge. It is a closed loop made up of four resistors P, Q, R and S. A source of emf (battery) is connected across AC and a galvanometer is connected across BD. Three of the four resistors are known whose values are so adjusted that the galvanometer shows zero deflection. In this condition, Wheatstone bridge is said to be balanced.

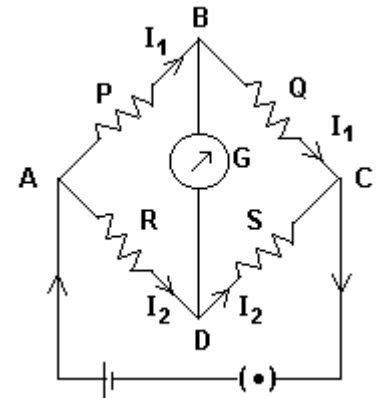

Applying Kirchhoff's second rule to the loop A - B - D - A under the balanced condition,

$$-P I_1 + R I_2 = 0 \quad \therefore P I_1 = R I_2 \quad \dots \dots (1)$$

Similarly, applying Kirchhoff's second rule to the loop B - C - D - B,

$$-Q I_1 + S I_2 = 0 \quad \therefore Q I_1 = S I_2 \quad \dots \dots (2)$$

Dividing equation (1) by equation (2), we have

$$\frac{P}{Q} = \frac{R}{S} \quad \dots \dots (3)$$

Hence by using the values of the three known resistors in the above equation, the value of the fourth unknown resistor can be calculated.

The circuit constructed as shown in the adjoining figure is used in the laboratory to find the value of unknown resistance using Wheatstone bridge principle.

Here, a constantan resistive wire of uniform diameter is used in place of resistors R and S. The wire is mounted on a wooden plank alongwith a meter rule. Copper strips are connected at the ends A and B of the wire as shown in the figure. The terminals on this strip are connected to a battery. Another copper strip is fixed between these two strips forming two gaps. In one gap, an unknown resistor P is connected and in the other a known resistor Q is connected. One end of a galvanometer is connected to the mid-point D of this strip and the other end to a jockey which can slide on the wire in such a way that galvanometer shows zero deflection. If null point is obtained at C such that AC = l_1 and CB = l_2 , then from equation (3) above,

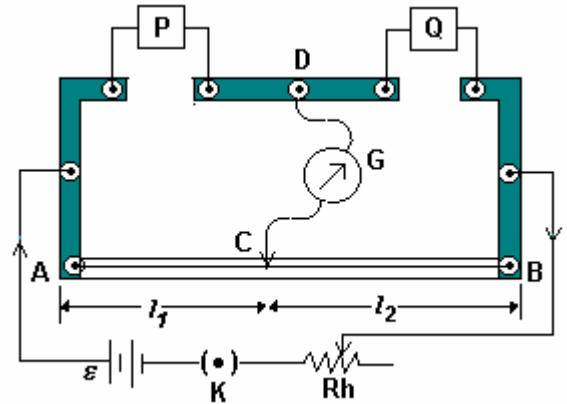

$$\frac{P}{Q} = \frac{\rho l_1}{\rho l_2} \quad \therefore P = \frac{l_1}{l_2} Q$$

The value of $l_1 : l_2$ is found out for different values of Q from which average value of P is calculated.

End correction:

Due to copper strips at A and B, additional resistances get introduced in the circuit. Let α and β be the additional lengths of the wire representing these resistances. If l_1 and $100 - l_1$ are the lengths of wire on either side of the jockey in the balanced condition on taking the known resistances P_1 and Q_1 in the gaps, then

$$\frac{P_1}{Q_1} = \frac{l_1 + \alpha}{100 - l_1 + \beta} \quad \dots \quad (1)$$

Now, if l_2 and $100 - l_2$ are the corresponding lengths of wire in the balanced condition on interchanging the resistances P_1 and Q_1 in the gaps, then

$$\frac{Q_1}{P_1} = \frac{l_2 + \alpha}{100 - l_2 + \beta} \quad \dots \quad (2)$$

Solving equations (1) and (2), we get $\alpha = \frac{Q_1 l_1 - P_1 l_2}{P_1 - Q_1}$ and $\beta = \frac{P_1 l_1 - Q_1 l_2}{P_1 - Q_1} - 100$

These equations can be used to make the necessary end corrections.

3.10 (d) Potentiometer

The terminal voltage of the battery is given by $V = \epsilon - Ir$.

When we try to measure emf of the battery using a voltmeter, some current does flow through the battery. Hence, voltmeter measures terminal voltage V and not the emf ϵ . If the term Ir in the above equation is zero, then only the voltmeter can measure emf of the battery. As internal resistance of the battery is not zero, this means that the current I must be zero. This is not possible in a voltmeter. Hence voltmeter cannot measure emf of the battery.

To measure emf of the battery, a device known as potentiometer is used.

Principle of potentiometer

Potentiometer is such an arrangement in which one can obtain a continuously varying p.d., the principle of which can be utilized to measure emf of a battery with a suitable circuit.

A battery having emf ϵ and internal resistance r is connected in series with a resistance box R and a long resistive wire of uniform diameter (so that its resistance per unit length is constant).

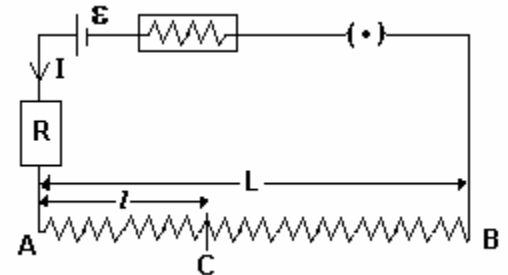

Let L = length of the resistive wire AB and
 ρ = resistance per unit length of the wire.
 $\therefore L\rho$ = resistance of the wire AB .

If R is the resistance of the resistance box, then the current I flowing through the wire is

$$I = \frac{\epsilon}{R + L\rho + r}, \text{ where } r \text{ is the internal resistance of the battery.}$$

Hence, potential difference across wire AC is given by

$$V_l = I\rho l = \frac{\epsilon\rho}{R + L\rho + r} l, \text{ where } l \text{ is the length of the wire } AC.$$

The potential difference per unit length = $\frac{V_l}{l}$ is called the potential gradient. Its unit is V/m .

The above equation shows that the potential difference between any two points of the potentiometric wire is directly proportional to the length of the wire between the two points. Points A and C behave like the positive and negative poles of a battery. By changing the position of C , one can obtain the continuously varying emf.

Use of Potentiometer: Comparison of emfs of Two Cells

Let ϵ_1 and ϵ_2 be the emfs of the two batteries. First, the positive pole of the battery having emf ϵ_1 is connected to point A while the negative pole is connected to jockey through a sensitive galvanometer. When jockey is slid on the wire, galvanometer shows zero deflection at the position C_1 of the jockey. In this balanced condition, potential difference between the points A and C_1 is equal to the emf ϵ_1 of the battery.

$$\therefore \epsilon_1 = \frac{\epsilon \rho}{R + L\rho + r} l_1 \dots \dots (1)$$

Similarly, if we get null point at C₂ with battery having emf ϵ_2 , then we have

$$\epsilon_2 = \frac{\epsilon \rho}{R + L\rho + r} l_2 \dots \dots (2)$$

Dividing equation (1) by equation (2),

$$\frac{\epsilon_1}{\epsilon_2} = \frac{l_1}{l_2}$$

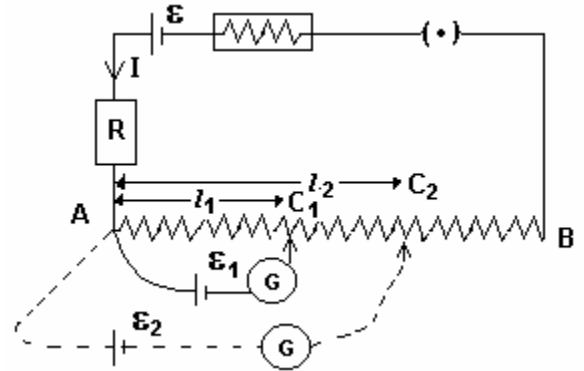

This equation is used to compare emfs of the two batteries. It can also be used to find out the emf of any battery by comparing it with another standard battery.

One can obtain any desired value of the potential difference between ends of the wire AB of the potentiometer by selecting an appropriate value of R in the resistance box and thereby measure very small emf of the order of mV or even μV .

3.11 Combination of Cells

There are three ways in which cells can be connected:

- (1) Series connection, (2) Parallel connection and (3) Mixed connection.

Mixed Connection:

Let n = number of cells having emfs $\epsilon_1, \epsilon_2, \dots, \epsilon_n$ and internal resistances r_1, r_2, \dots, r_n connected in series and
 m = number of parallel connections of such series of cells.

For each series of cells, total emf is $\sum_{i=1}^n \epsilon_i$ and total internal resistance is $\sum_{i=1}^n r_i$.

For the mixed connection, the total emf is $\sum_{i=1}^n \epsilon_i$ and net internal resistance is $\frac{1}{m} \sum_{i=1}^n r_i$.

$$\therefore \text{Current } I = \frac{\text{total emf}}{\text{total resistance}} = \frac{\sum \epsilon_i}{R + \frac{1}{m} \sum r_i}$$

If $\epsilon_i = \epsilon$ and $r_i = r$, then $I = \frac{mn\epsilon}{mR + nr}$,

where R is the resistance in the circuit.

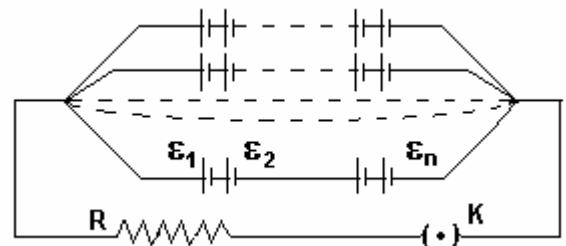

To determine how to arrange given total number of cells $mn = x$ in the above mixed connection of cells for given external resistance R so that the current in the circuit becomes maximum, we note that

$$I = \frac{mn\epsilon}{(\sqrt{nr} - \sqrt{mR})^2 + 2\sqrt{mnrR}} \quad \text{which means that for current to be maximum,}$$

$\sqrt{nr} - \sqrt{mR} = 0$, or $nr = mR$ or $R = nr/m$, i.e., when the given number of cells are so arranged that their equivalent resistance equals the given fixed external resistance.

Solving $mn = x \dots (1)$ with $nr = mR \dots (2)$, we get $m = \sqrt{\frac{xr}{R}}$ and $n = \sqrt{\frac{xR}{r}}$

and the value of the maximum current is

$$I_{\max} = \frac{\epsilon}{2} \sqrt{\frac{x}{rR}}$$

(Note: Treatment of maximum current given in example 22 of the text-book and many other publications is logically defective. Important point to be noted here is that R is not variable. If R were to be variable, then the maximum current will be when R is zero. m and n are the variables whose values are to be obtained as above. If the above equations do not give integer values of m and n, then finding maximum current will involve examining several alternatives.)

Series Connection: For only one series of cells, $m = 1$, $I = \frac{\sum \epsilon_i}{R + \sum r_i}$

Parallel Connection: For m parallel connections each having one cell, $n = 1$, $I = \frac{\epsilon_i}{R + \frac{r_i}{m}}$

Parallel Connection of Cells with different emfs and different internal resistances:

Two cells having emfs ϵ_1 and ϵ_2 and internal resistances r_1 and r_2 are connected in parallel as shown in the figure.

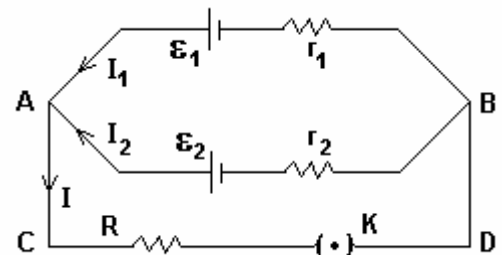

Applying Kirchhoff's first rule at junction point A,

$$I = I_1 + I_2 \dots \dots (1)$$

Applying Kirchhoff's second rule to the loop ACDB ϵ_1 A,

$$IR + I_1 R_1 = \epsilon_1 \quad \therefore I_1 = \frac{\epsilon_1 - IR}{r_1} \quad \text{and similarly,} \quad \therefore I_2 = \frac{\epsilon_2 - IR}{r_2} \dots \dots (2)$$

Putting, values of I_1 and I_2 from equation (2) in equation (1),

$$I = \frac{\epsilon_1 - IR}{r_1} + \frac{\epsilon_2 - IR}{r_2} \Rightarrow I = \frac{\frac{\epsilon_1}{r_1} + \frac{\epsilon_2}{r_2}}{1 + \frac{R}{r_1} + \frac{R}{r_2}}$$

If n cells are connected in parallel in the above arrangement, then $I = \frac{\sum_{i=1}^n \frac{\epsilon_i}{r_i}}{1 + R \sum_{i=1}^n \frac{1}{r_i}}$